

Given name/s

Family name

Teacher

Class

School name

Common internal assessment 2025 — Ancillary phase

Question and response book

Essential Mathematics

Time allowed

- Perusal time — 5 minutes
- Working time — 60 minutes

General instructions

- Answer all questions in this question and response book.
- Write using black or blue pen.
- QCAA-approved calculator permitted.
- Ruler required.
- QCAA formula book provided.
- Planning paper will not be marked.

Part A: Simple (40 marks)

- 9 short response questions

Part B: Complex (10 marks)

- 2 short response questions





DO NOT WRITE ON THIS PAGE
THIS PAGE WILL NOT BE MARKED



Instructions

- Questions worth more than one mark require mathematical reasoning and/or working to be shown to support answers.
- If you need more space for a response, use the additional pages at the back of this book.
 - On the additional pages, write the question number you are responding to.
 - Cancel any incorrect response by ruling a single diagonal line through your work.
 - Write the page number of your alternative/additional response, i.e. See page ...
 - If you do not do this, your original response will be marked.

Part A: Simple

- This part has nine questions and is worth 40 marks.
-

DO NOT WRITE ON THIS PAGE

THIS PAGE WILL NOT BE MARKED

Do not write outside this box.

QUESTION 1 (4 marks)

A tiler is hired to lay outdoor pavers of the shape shown.

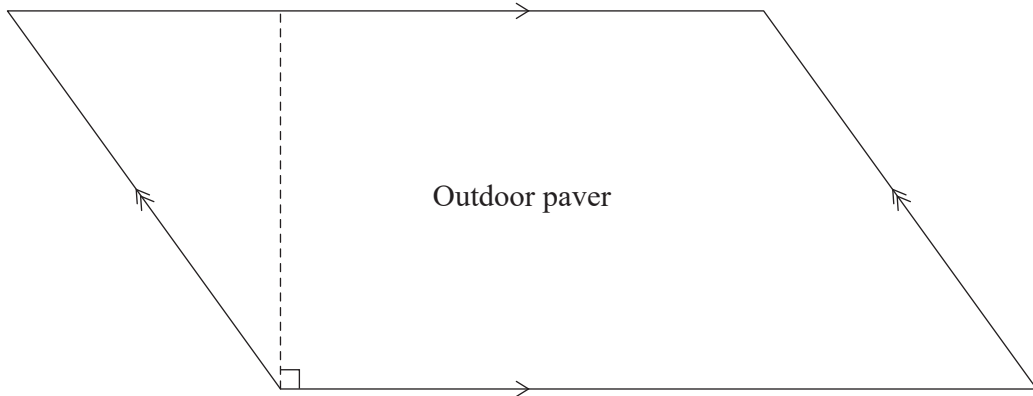

Scale 1:5

- a) Determine the actual base length of the outdoor paver in centimetres. *[1 mark]*

- b) Determine the actual perpendicular height of the outdoor paver in centimetres. *[1 mark]*

- c) Determine the actual area of the outdoor paver in square centimetres. *[2 marks]*

Do not write outside this box.

QUESTION 2 (6 marks)

A farmer is making a rectangular gate with a diagonal brace, as shown.

Not to scale

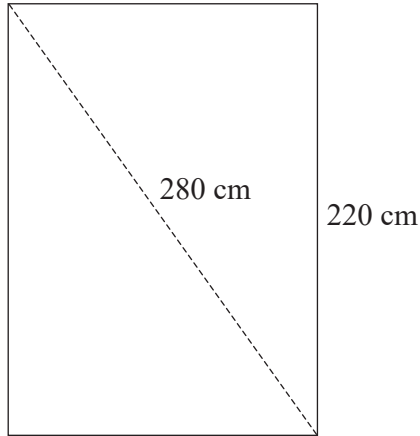

- a) Use Pythagoras' theorem to calculate the width of the gate, rounded to the nearest centimetre.

[3 marks]

- b) Calculate the perimeter of the rectangular gate in metres.

[3 marks]

Do not write outside this box.

QUESTION 3 (2 marks)

Sunscreen is sold in 500 mL bottles. One application of sunscreen is 15 mL.

Approximately how many applications of sunscreen are in one bottle, rounded to the nearest whole number?

Do not write outside this box.

QUESTION 4 (6 marks)

A teacher records the time (minutes) that students spend travelling to school, as shown.

Student	A	B	C	D	E	F	G	H	I	J	K	L	M
Time	14	8	21	12	7	15	22	35	3	8	28	22	17

a) Calculate the mean travel time for the students.

[2 marks]

b) Determine the median travel time for the students.

[2 marks]

c) Complete the five-number summary table for the time students spend travelling to school by writing an appropriate label or value in each empty cell of the table.

[2 marks]

	Q ₁		Q ₃	Maximum
	8		22	

Do not write outside this box.

QUESTION 5 (5 marks)

An artist is transporting a recycled plastic sculpture in the shape of a square-based pyramid, as shown.

Not to scale

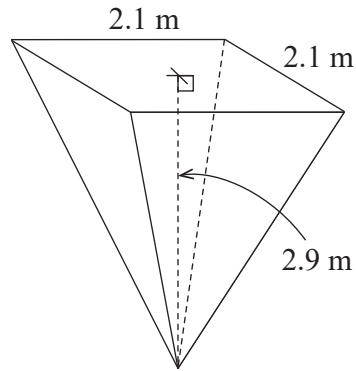

- a) Use leading-digit approximation to estimate the volume of the recycled plastic sculpture in cubic metres. *[2 marks]*

The recycled plastic weighs approximately 900 kilograms per cubic metre (kg/m^3).

- b) Determine the approximate mass of the recycled plastic sculpture in kilograms. *[1 mark]*

Do not write outside this box.

c) Convert the approximate mass of the recycled plastic sculpture from kilograms to tonnes. *[1 mark]*

The cost to transport the recycled plastic sculpture is \$300 per tonne.

d) Determine the approximate total cost for transporting the recycled plastic sculpture. *[1 mark]*

Do not write outside this box.

QUESTION 6 (3 marks)

A flower bed is in the shape of a sector, as shown.

Not to scale

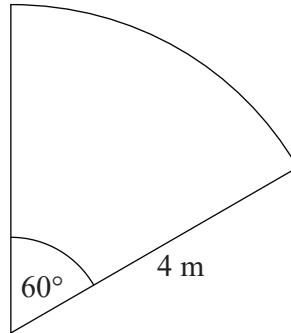

- a) Calculate the arc length of the flower bed in metres, rounded to two decimal places. *[2 marks]*

- b) Determine the perimeter of the flower bed in metres. *[1 mark]*

Do not write outside this box.

QUESTION 7 (3 marks)

The number of warm-up laps around the oval for 12 soccer players is shown.

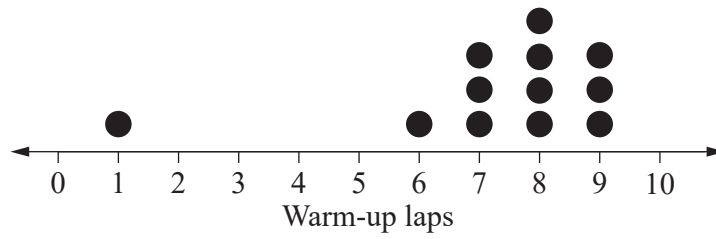

a) Identify the mode number of warm-up laps. *[1 mark]*

b) Describe two different features of the spread of the data. *[2 marks]*

Do not write outside this box.

QUESTION 8 (6 marks)

A fish tank with a lid is in the shape of a cube, as shown.

Not to scale

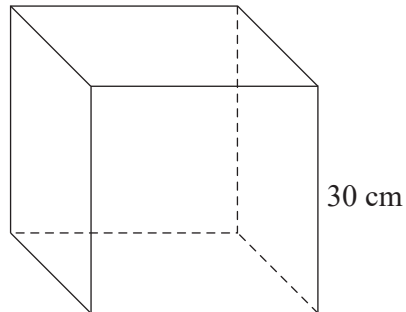

- a) How many faces does the fish tank have?

[1 mark]

The frame of the fish tank is made from aluminium rods.

- b) Calculate the total length of aluminium rods used to construct the frame of the fish tank in centimetres.

[2 marks]

- c) Calculate the volume of the fish tank in cubic centimetres.

[2 marks]

Do not write outside this box.

The water inside the fish tank has a volume of $20\,250\text{ cm}^3$.

d) Determine what fraction of the tank's volume is occupied by water.

[1 mark]

Do not write outside this box.

QUESTION 9 (5 marks)

A company makes rectangular fridge calendars with triangular magnets on the back, as shown.

Not to scale

Fridge calendar (back view)

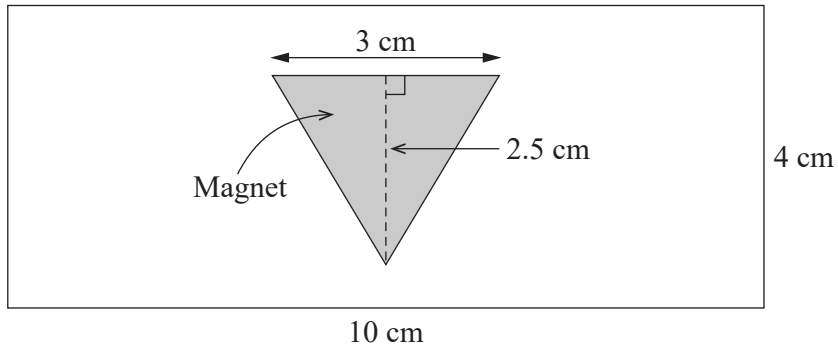

- a) Calculate the area of the entire fridge calendar in square centimetres.

[2 marks]

- b) Calculate the area of the magnet in square centimetres.

[2 marks]

Do not write outside this box.

The company claims that the magnet covers more than 20% of the back of the fridge calendar.

- c) Explain why the company's claim is not reasonable. Your response must include mathematical reasoning.

[1 mark]

Do not write outside this box.

Part B: Complex

- This part has two questions and is worth 10 marks.

QUESTION 10 (5 marks)

A family has a rectangular-based prism swimming pool, as shown. They want to put a waterproof sealant on the pool's base and four inside walls.

Not to scale

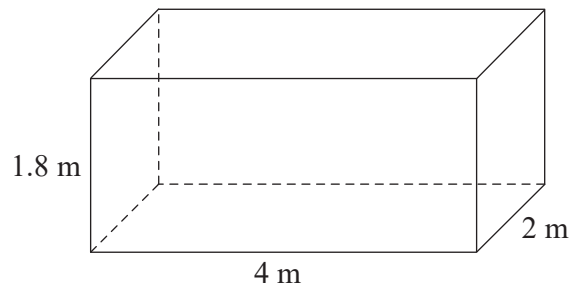

One litre of waterproof sealant costs \$30.50 and covers 6.2 m^2 . The family has budgeted \$130 to buy the waterproof sealant.

Determine if the family can buy enough waterproof sealant.

Do not write outside this box.



Do not write outside this box.





© State of Queensland (QCAA) 2024

Licence: <https://creativecommons.org/licenses/by/4.0> | Copyright notice: www.qcaa.qld.edu.au/copyright — lists the full terms and conditions, which specify certain exceptions to the licence. | Attribution: © State of Queensland (QCAA) 2024